

HARPER TRUCKS INC.

PJD NYLON JUNIOR CONVERTIBLE SERIES

INSTRUCTIONS

PARTS LISTING

| QTY | DESCRIPTION | P/N |
|-----|-------------|----------------|
| A | HEAD | PGDTBLK-6 |
| B | SIDE FRAME | PJDBLK-2L & 2R |
| C | CROSSMEMBER | PGBLK-5 |
| D | CASTER | WH 23A |

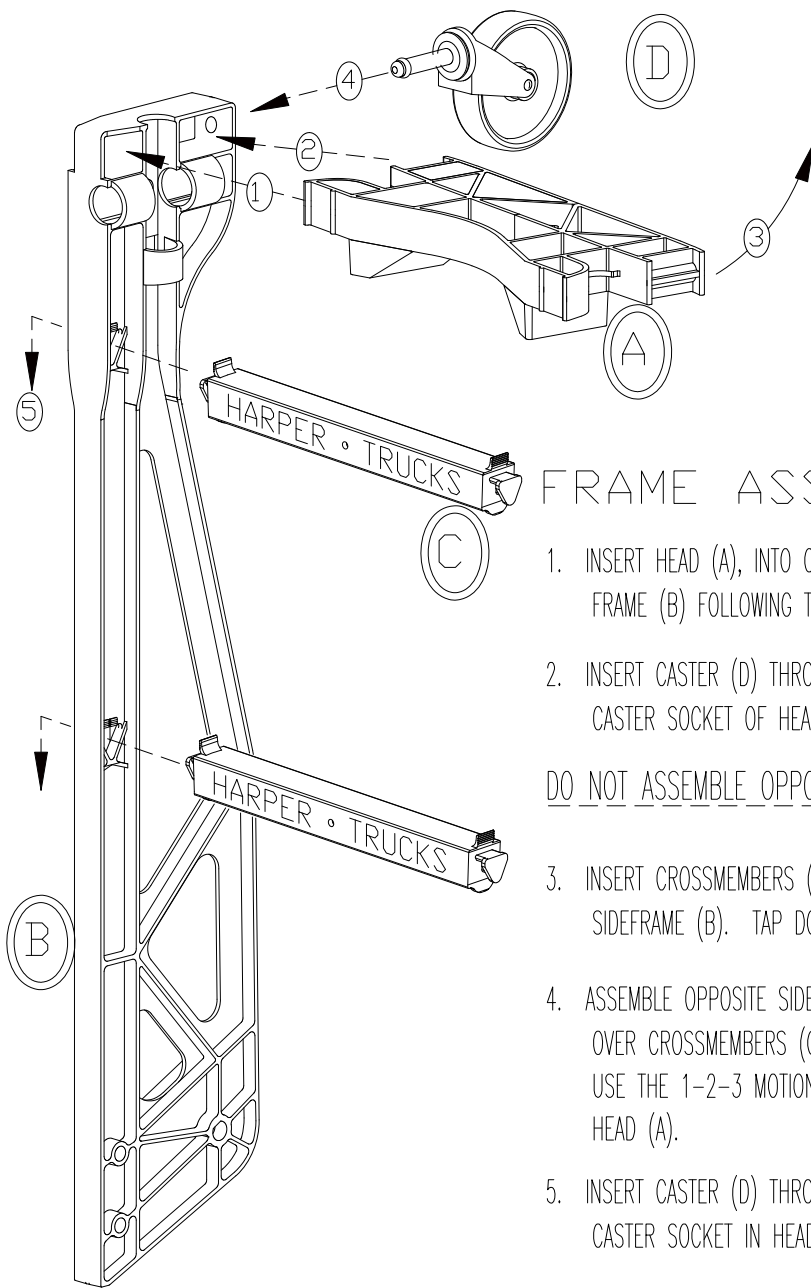

FRAME ASSEMBLY

1. INSERT HEAD (A), INTO ONE SIDE FRAME (B) FOLLOWING THE 1-2-3 MOTION.
 2. INSERT CASTER (D) THROUGH SIDE FRAME (B) & CASTER SOCKET OF HEAD (A).
- DO NOT ASSEMBLE OPPOSITE SIDE AT THIS TIME!
3. INSERT CROSSMEMBERS (C) WITH NAME FORWARD, INTO THE SIDEFAME (B). TAP DOWNWARD LIGHTLY TO SECURE TABS.
 4. ASSEMBLE OPPOSITE SIDE FRAME (B1) OVER CROSSMEMBERS (C) & HEAD (A). USE THE 1-2-3 MOTION TO INSTALL OVER THE HEAD (A).
 5. INSERT CASTER (D) THROUGH SIDE FRAME (B & B1) & CASTER SOCKET IN HEAD (A).
 6. TAP DOWN ON CROSSMEMBERS TO LOCK IN PLACE.

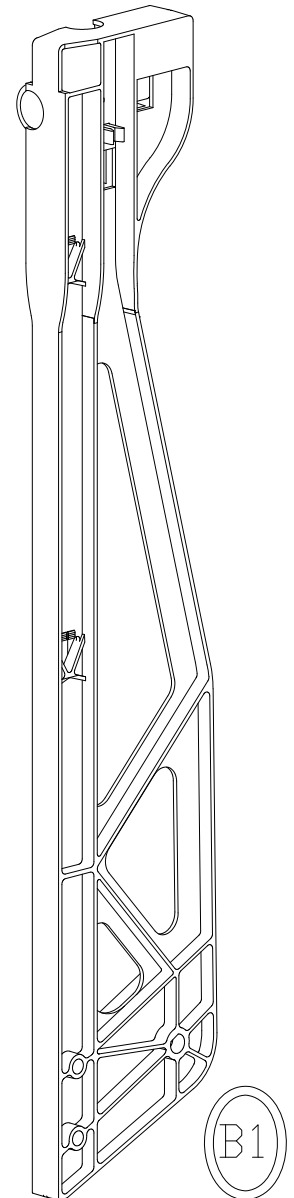

300 LBS CAPACITY IN 2-WHEEL POSITION

