

HARPER TRUCKS INC.

PGD NYLON SENIOR CONVERTIBLE SERIES INSTRUCTIONS

PARTS LISTING

P/N	QTY	DESCRIPTION
A	1	HEAD
B	2	SIDE FRAME
C	3	CROSSMEMBER
D	2	CASTER

**600 LBS CAPACITY IN
2-WHEEL POSITION**

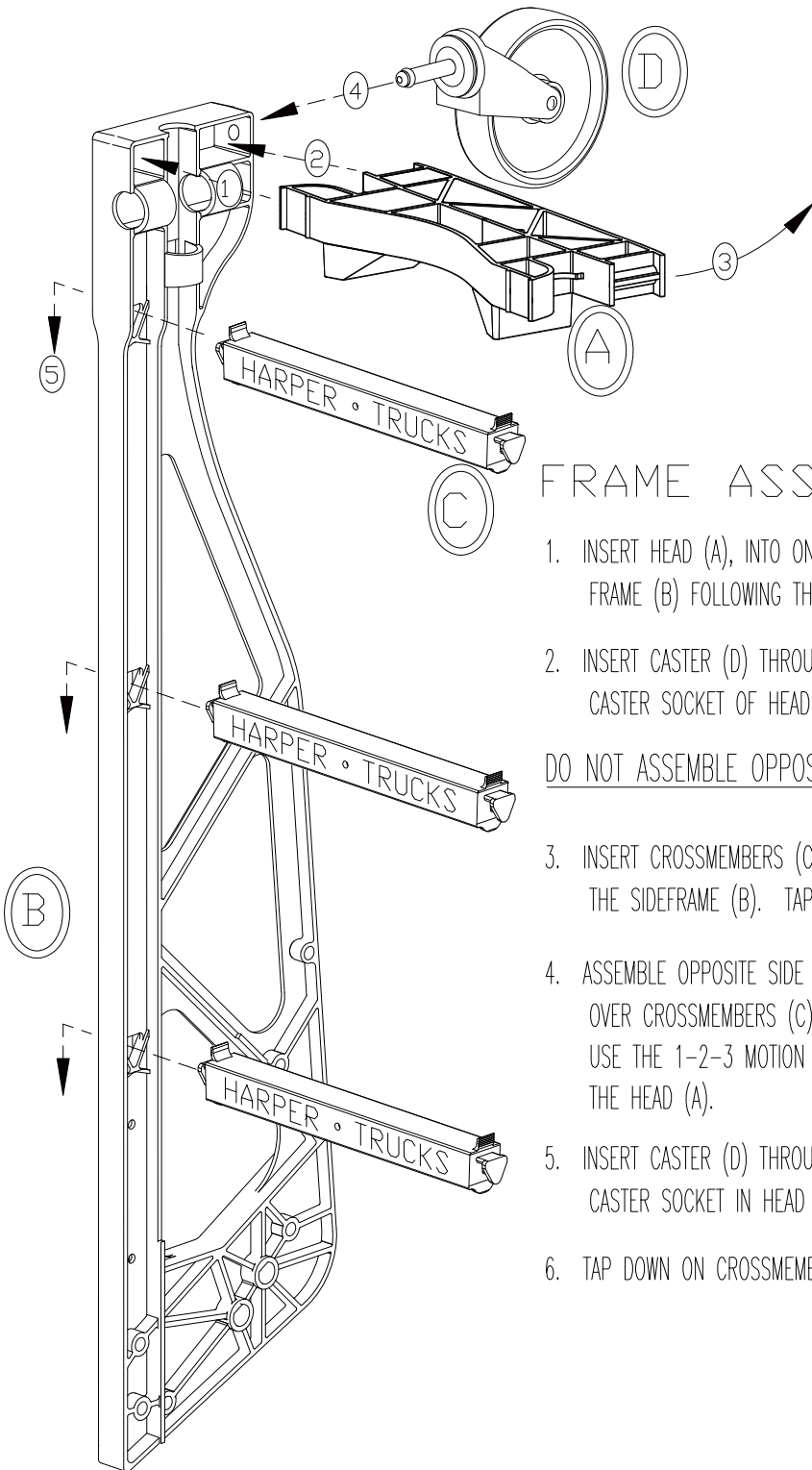

FRAME ASSEMBLY

1. INSERT HEAD (A), INTO ONE SIDE FRAME (B) FOLLOWING THE 1-2-3 MOTION.
2. INSERT CASTER (D) THROUGH SIDE FRAME (B) & CASTER SOCKET OF HEAD (A).

DO NOT ASSEMBLE OPPOSITE SIDE AT THIS TIME!

3. INSERT CROSSMEMBERS (C) WITH NAME FORWARD, INTO THE SIDEFRAME (B). TAP DOWNWARD LIGHTLY TO SECURE TABS.
4. ASSEMBLE OPPOSITE SIDE FRAME (B1) OVER CROSSMEMBERS (C) & HEAD (A). USE THE 1-2-3 MOTION TO INSTALL OVER THE HEAD (A).
5. INSERT CASTER (D) THROUGH SIDE FRAME (B1) & CASTER SOCKET IN HEAD (A).
6. TAP DOWN ON CROSSMEMBERS TO LOCK IN PLACE.

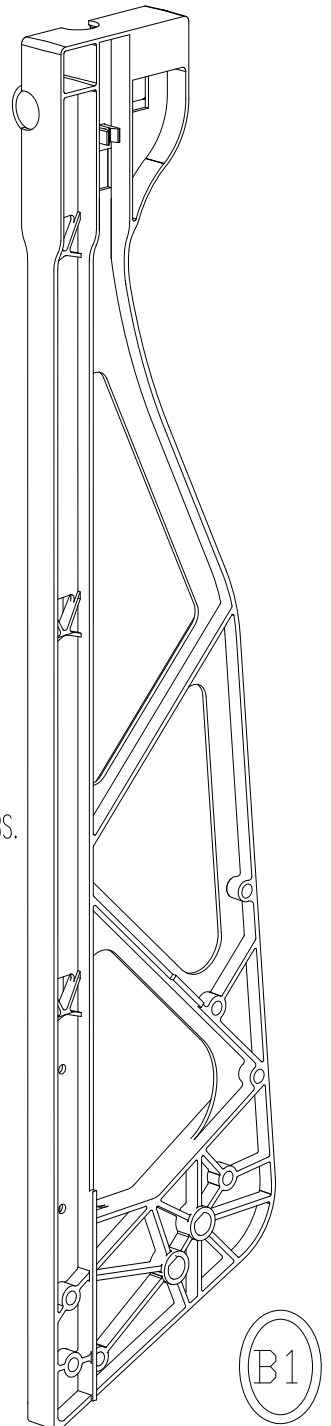

BASE/AXLE ASSEMBLY

1. FASTEN THE BASE PLATE (E) TO THE FRAME WITH 4 BOLTS (F) AND NUTS (G).
2. SLIDE AXLE (H) THROUGH SIDEFRAME (B) AXLE HOLES AS SHOWN. INSERT 2 WASHERS (K) ON THE AXLE BETWEEN THE FRAMES.
3. INSTALL 2 COTTER PINS (L) IN THE AXLE BETWEEN THE SIDEFRAMES WITH THE WASHER BETWEEN THE COTTER PIN AND SIDEFRAME.

4. ASSEMBLE THE WHEELS ONTO THE AXLE WITH 2 WASHERS (K) ON THE INSIDE AND 1 WASHER (K) ON THE OUTSIDE OF THE WHEEL. SECURE WITH A COTTER PIN (L) THROUGH EACH END OF THE AXLE (H).

PARTS LISTING			P/N	QTY	DESCRIPTION
P/N	QTY	DESCRIPTION			
E	1	BASE PLATE	J	2	WHEEL
F	4	BOLT	K	8	WASHER
G	4	NUT	L	4	COTTER PIN
H	1	AXLE	M	1	HANDLE
			N	2	LOCK PIN

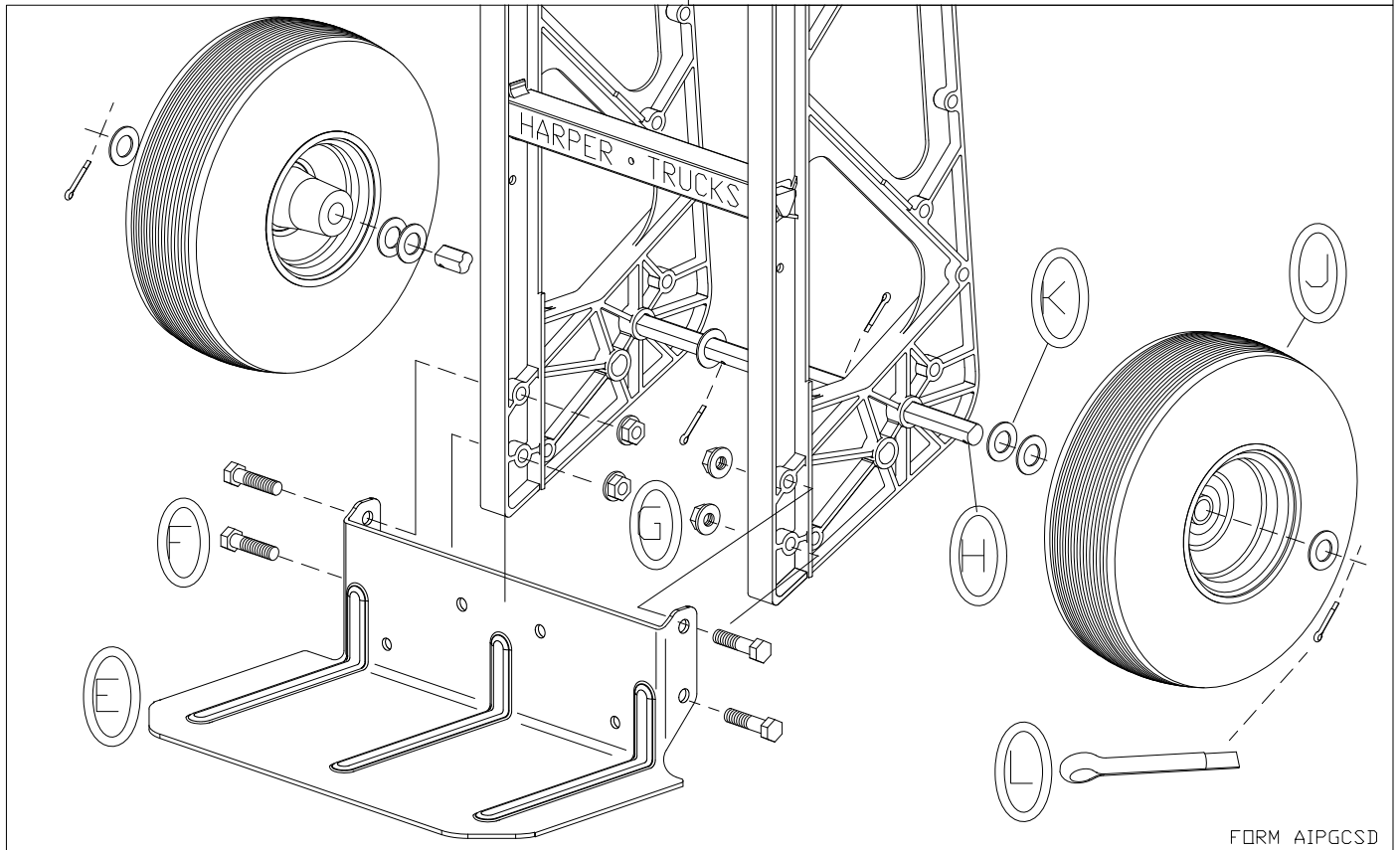

HANDLE OPTIONS:

TWO WHEELED HANDTRUCK

1. SLIDE HANDLE INTO FRAME HOLE (T) UNTIL UPPER HOLE ALIGNS.
2. INSERT LOCK PINS THROUGH HOLE (P) AND SNAP INTO FRAME CLIP.

FOUR WHEELED HANDTRUCK

1. SLIDE HANDLE INTO FRAME HOLE (R) UNTIL UPPER HOLE ALIGNS.
2. INSERT LOCK PINS THROUGH HOLE (P) AND SNAP INTO FRAME CLIP.

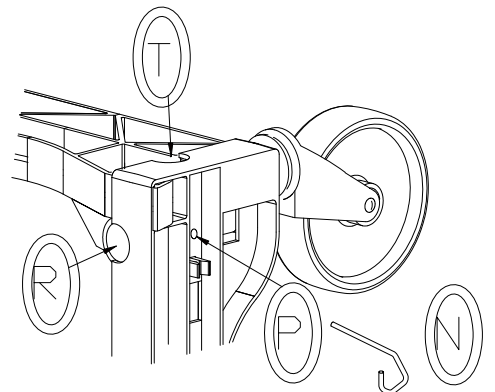

PROUDLY MADE IN WICHITA, KANSAS
 FOR ASSISTANCE CALL 1-800-835-4099
 OR VISIT WWW.HARPERTRUCKS.COM